



# ecocirc BASIC and PREMIUM

HIGH EFFICIENCY RESIDENTIAL CIRCULATORS FOR HVAC APPLICATIONS

# How can efficiency even work harder?

THE SIMPLE SPHERICAL MOTOR DESIGN WITH THE PATENTED ANTI-BLOCK TECHNOLOGY

## Improved pump housing.

The cast iron pump housing is completely cathaphoresis coated and is therefore resistant to corrosion. In drinkable water applications, a new AISI 304 stainless steel pump housing is available (ecocirc BASIC N models).



## Spherical rotor.

ecocirc BASIC and PREMIUM are provided with a unique spherical motor design, with only one single bearing. Spherical motor pumps are shaftless, and therefore whisper quiet over the pump's lifetime. Should the rotor become blocked, emergency software vibrates the rotor to avoid further blocking. Anti-Block Technology enables separation of the magnetic chamber from the flow, preventing magnetite and sludge from blocking and damaging the pump.



## Dry-run protection and enhanced motor technology.



ecocirc BASIC and PREMIUM circulators come with an internal temperature sensor as standard which measures the electronic component temperature directly. The pump reduces speed continuously between electronic temperatures of between 105°C to 115°C. The pump stops automatically at 125°C, and restarts again after cooling down to 115°C. In addition, the inrush-current limitation of 6,5 Amp protects older external heating controls that may be installed on site.



## Easy settings.

One single knob serves all needs, from working mode selection to automatic air purge.

The multi-colour LED inside the transparent knob indicates the chosen control option:

  **white:**  
stepless fixed speed, especially for boiler feed, single-pipe heating systems, systems with hydraulic separator;

  **blue:**  
automatic proportional pressure control  $\Delta p-v$ , especially for thermostatic radiator valves;

  **green:**  
automatic constant pressure control  $\Delta p-c$ , especially for underfloor heating systems (only ecocirc PREMIUM models)

In addition, a blink code via the LED highlights potential error messages. The corresponding error code is shown on the display.



## Quick electric connection.

A plug is provided as standard with all models, so no tools are required for assembly. By turning the stator via the screw ring, the plug can be fixed in any position, making the installation simple in even the hardest and tightest environments (excludes ecocirc BASIC N models).

## Automatic air purge.

Simply turn the knob towards the air purge symbol for more than 5 seconds. This will start the automatic air purging, no matter which control option had been chosen before. This will effectively remove the air from the inner of the pump. The circulator will return automatically to all its previously chosen settings after having finished this service mode.

# ecocirc BASIC

The Lowara ecocirc BASIC provides rapid amortisation and short payback times with no compromise on reliability or efficiency - all with a clear focus on core functionality.

## Two stepless control options

- stepless fixed speed
- automatic proportional pressure control  $\Delta p-v$

High efficiency pumps with ECM technology and permanent magnet rotor

Suitable for radiant heating, underfloor and surface heating, boiler feed, solar stations and sanitary applications (ecocirc BASIC N)

Cataphoresis coated cast iron housing



Fixed speed mode

Proportional pressure mode

Antiblock technology

Automatic air purge

Plug



## ecocirc BASIC N

AISI 304 stainless steel pump housing



ecocirc BASIC	EEI	Max head (m)	Port to port (mm)	Threaded connections	Pump housing	
					Cast iron	Stainless steel
ecocirc BASIC 15-4/130 (N)	≤0,20	4	130	G 1" - R <sub>p</sub> 1/2	X	X
ecocirc BASIC 20-4/130	≤0,20	4	130	G 1" 1/4 - R <sub>p</sub> 3/4	X	
ecocirc BASIC 20-4/150 N	≤0,20	4	150	G 1" 1/4 - R <sub>p</sub> 3/4		X
ecocirc BASIC 25-4/130 (N)	≤0,20	4	130	G 1" 1/2 - R <sub>p</sub> 1	X	X
ecocirc BASIC 25-4/180 (N)	≤0,20	4	180	G 1" 1/2 - R <sub>p</sub> 1	X	X
ecocirc BASIC 32-4/180 (N)	≤0,20	4	180	G 2" - R <sub>p</sub> 1 1/4	X	X
ecocirc BASIC 15-6/130 (N)	≤0,23	6	130	G 1" - R <sub>p</sub> 1/2	X	X
ecocirc BASIC 20-6/130	≤0,23	6	130	G 1" 1/4 - R <sub>p</sub> 3/4	X	
ecocirc BASIC 20-6/150 N	≤0,23	6	150	G 1" 1/4 - R <sub>p</sub> 3/4		X
ecocirc BASIC 25-6/130 (N)	≤0,23	6	130	G 1" 1/2 - R <sub>p</sub> 1	X	X
ecocirc BASIC 25-6/180 (N)	≤0,23	6	180	G 1" 1/2 - R <sub>p</sub> 1	X	X
ecocirc BASIC 32-6/180 (N)	≤0,23	6	180	G 2" 1/2 - R <sub>p</sub> 1 1/4	X	X

# ecocirc PREMIUM



All Lowara ecocirc PREMIUM circulators have three control options, a plug that does not require a tool for assembly, and a multi-display mounted on the end cap as standard.



### Multi-Display

The automatically alternating display shows either the currently consumed power, the pump head or the flow rate.

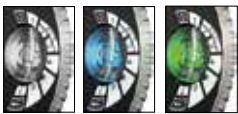

### Three stepless control options

- stepless fixed speed
- automatic proportional pressure control  $\Delta p-v$
- automatic constant pressure control  $\Delta p-c$

### Plug, no tools required for assembly

An easy and quick electrical connection. The female plug is compatible with male plugs from previous on-site installations third-party circulators. By turning the stator via the screw ring, the plug can be fixed in any position, making installation even in the hardest and tightest environment easy.



High efficiency pumps with ECM technology and permanent magnet rotor

Suitable for radiant heating, underfloor and surface heating, boiler feed and solar stations

Cataphoresis coated cast iron pump housing

Fixed speed mode

Proportional pressure mode

Antiblock technology

Automatic air purge

Plug

Constant pressure mode, suitable especially for underfloor heating systems

Digital display that automatically alternates between power consumption (W), head (m), and flow-rate (m<sup>3</sup>/h). The display provides detailed information on the air purge mode status as well as detailed error messages.

ecocirc BASIC	EEI	Max head (m)	Port to port (mm)	Threaded connections	Pump housing	
					Cast iron	Stainless steel
ecocirc PREMIUM 15-4/130	≤0,20	4	130	G 1" - Rp 1/2	X	
ecocirc PREMIUM 20-4/130	≤0,20	4	130	G 1" 1/4 - Rp 3/4	X	
ecocirc PREMIUM 25-4/130	≤0,20	4	130	G 1" 1/2 - Rp 1	X	
ecocirc PREMIUM 25-4/180	≤0,20	4	180	G 1" 1/2 - Rp 1	X	
ecocirc PREMIUM 32-4/180	≤0,20	4	180	G 2" - Rp 1 1/4	X	
ecocirc PREMIUM 15-6/130	≤0,23	6	130	G 1" - Rp 1/2	X	
ecocirc PREMIUM 20-6/130	≤0,23	6	130	G 1" 1/4 - Rp 3/4	X	
ecocirc PREMIUM 25-6/130	≤0,23	6	130	G 1" 1/2 - Rp 1	X	
ecocirc PREMIUM 25-6/180	≤0,23	6	180	G 1" 1/2 - Rp 1	X	
ecocirc PREMIUM 32-6/180	≤0,23	6	180	G 2" - Rp 1 1/4	X	

## Identification code.

ecocirc BASIC 25 - 4 / 130 N

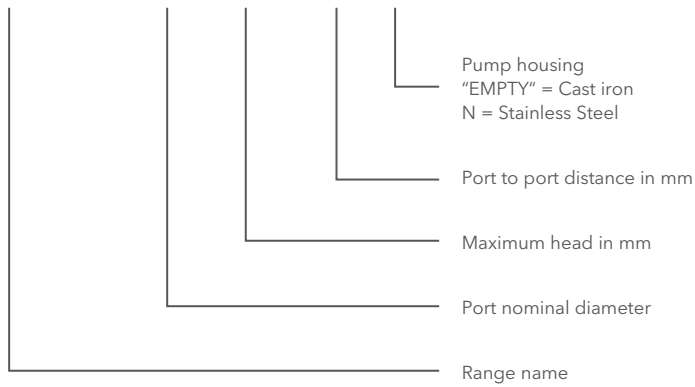

## Technical data.

Motor design	Electronically commutated, shaftless spherical motor design with permanent magnetic rotor
Maximum operating pressure	10 bar (PN 10)
Electric supply	200-240 V, 50/60 Hz
Power consumption	-4/ models: 4 - 23 W -6/ models: 4 - 42 W
Pumped liquids	Heating water according to VDI 2035 Water/glycol mixtures*
Temperature of pumped liquid	-10°C ** to + 110°C
IP protection	IP 44
Insulation class	F

\*check hydraulic performance with more than 20% glycol  
\*\*not freezing

## Pump curves.



stepless fixed speed, especially for boiler feed, single-pipe heating systems, systems with hydraulic switch

automatic proportional pressure control  $\Delta p-v$ , especially for radiator heating

automatic constant pressure control  $\Delta p-c$ , especially for underfloor heating (available only in PREMIUM models)

### Lowara ecocirc and ecocirc PREMIUM - 4-meter versions

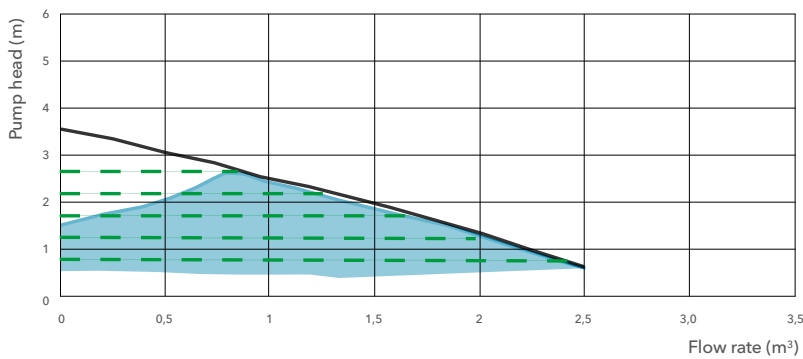

### Lowara ecocirc and ecocirc PREMIUM - 6-meter versions

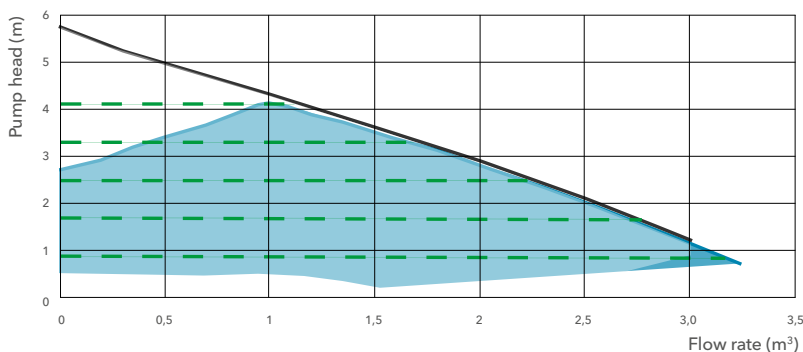

## Dimensional drawings.

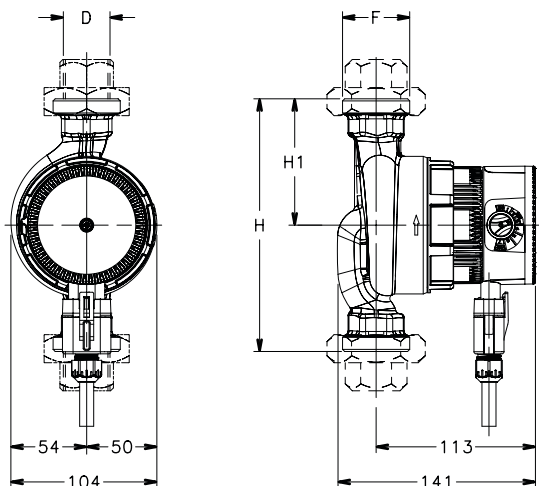

02884B\_A\_DD

**ecocirc BASIC / PREMIUM**

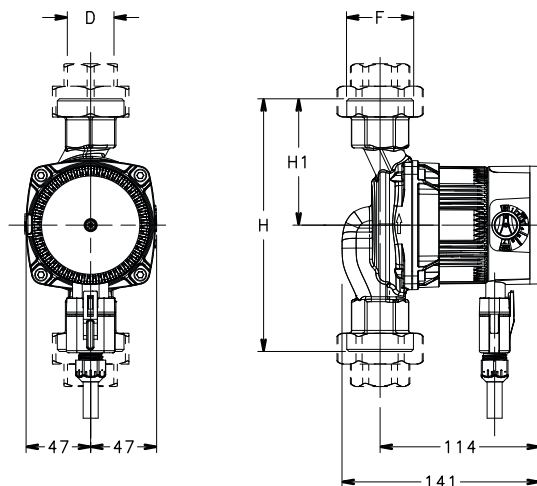

02884BN\_A\_DD

**ecocirc BASIC N**

ecocirc BASIC / PREMIUM	Dimensions (mm)		D	F	DN	Weight kg
	H	H1				
15-4/130 15-6/130	130	65	R <sub>p</sub> 1/2"	G 1"	15	1,9
20-4/130 20-6/130	130	65	R <sub>p</sub> 3/4"	G 1 1/4"	20	2,0
25-4/130 25-6/130	130	65	R <sub>p</sub> 1"	G 1 1/2"	25	2,1
25-4/180 25-6/180	180	90	R <sub>p</sub> 1"	G 1 1/2"	25	2,4
32-4/180 32-6/180	180	90	R <sub>p</sub> 1 1/4"	G 2"	32	2,6

ecocirc BASIC N	Dimensions (mm)		D	F	DN	Weight kg
	H	H1				
15-4/130 N 15-6/130 N	130	65	R <sub>p</sub> 1/2"	G 1"	15	1,9
20-4/150 N 20-6/150 N	150	75	R <sub>p</sub> 3/4"	G 1 1/4"	20	2,0
25-4/130 N 25-6/130 N	130	65	R <sub>p</sub> 1"	G 1 1/2"	25	2,1
25-4/180 N 25-6/180 N	180	90	R <sub>p</sub> 1"	G 1 1/2"	25	2,4
32-4/180 N 32-6/180 N	180	90	R <sub>p</sub> 1 1/4"	G 2"	32	2,6

## Installation positions.

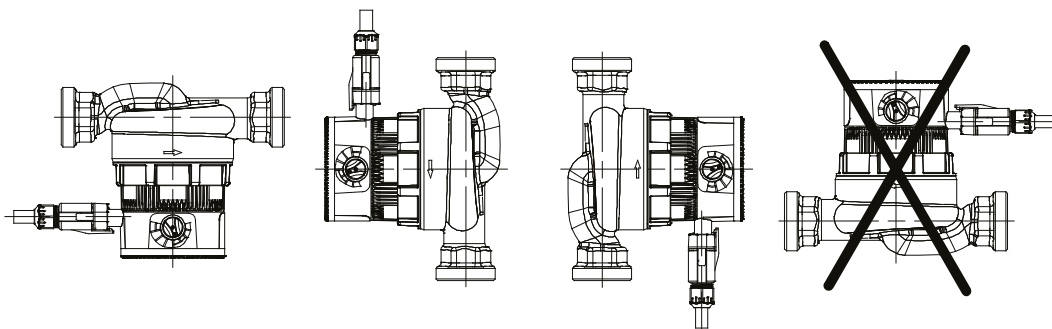

02889P\_A\_SC

# Xylem |'zīləm|

- 1) The tissue in plants that brings water upward from the roots;
- 2) a leading global water technology company.

We're a global team unified in a common purpose: creating advanced technology solutions to the world's water challenges. Developing new technologies that will improve the way water is used, conserved, and re-used in the future is central to our work. Our products and services move, treat, analyze, monitor and return water to the environment, in public utility, industrial, residential and commercial building services, and agricultural settings. With its October 2016 acquisition of Sensus, Xylem added smart metering, network technologies and advanced data analytics for water, gas and electric utilities to its portfolio of solutions. In more than 150 countries, we have strong, long-standing relationships with customers who know us for our powerful combination of leading product brands and applications expertise with a strong focus on developing comprehensive, sustainable solutions.

**For more information on how Xylem can help you, go to [www.xylem.com](http://www.xylem.com)**



For information and technical support  
Xylem Service Italia Srl

Via Dottor Vittorio Lombardi 14  
36075 - Montecchio Maggiore (VI) - Italy  
Tel. (+39) 0444 707111  
Fax (+39) 0444 491043  
[www.lowara.com](http://www.lowara.com)

Xylem Service Italia Srl reserves the right to make modification without prior notice.  
Lowara, Xylem are trademarks of Xylem Inc. or one of its subsidiaries.  
© 2017 Xylem, Inc.