

**Models:**

- M3K01 - 1 Speed Fan, 2 Cool, 2 Heat, 0 to 10V Analogue Output
- M3K02 - 1 Speed Fan, 2 Cool, 2 Heat, 0 to 10V Analogue Output with 365 Day Battery Backed Time Clock
- M3K03 - 3 Speed Fan, 1 Cool, 1 Heat, 0 to 10V Analogue Output
- M3K04 - 3 Speed Fan, 1 Cool, 1 Heat, 0 to 10V Analogue Output with 365 Day Battery Backed Time Clock

## Micro 3000 Controller

**Overview**

The *Micro 3000 Controller* is a standalone system designed to regulate temperature of a conditioned space. It consists of a *Controller* and a wall mounted *Control Station*. The communication between the *Controller* and the *Control Station* is achieved through a single communications channel, with data transfer occurring through the *Control Station's* power supply interface.

**Applications**

The Innotech *Micro 3000 Series Controllers* are designed to be used in commercial applications to provide complete control for air conditioning systems.

The *Micro 3000 Controller* 0 to 10VDC output is selectable for Economy Cycle (free cooling), Heating, Cooling or variable speed compressor applications.

**Features**

**Control Station**

- Icon based backlit Liquid Crystal Display (LCD)
- Modern, attractive enclosure design
- 4 x Universal inputs
- 1 x Onboard temperature sensor
- Push button interface
- 365 day battery backed time clock (M3K02 & M3K04)
- Up to 2 schedules per day and 20 yearly schedules (M3K02 & M3K04)

**Weekly and Yearly Schedules**

Schedules are set using the *Micro 3000 Control Station*. Only M3K02 & M3K04 models with Real Time Clocks can create schedules.

Refer to the *Micro 3000 Control Station User Instructions* for details on setting schedules.

**Controller**

- 1 x Temperature sensor for ambient temperature measurement
- 5 x Normally Open relays capable of switching 240VAC loads at 16A resistive, 6A inductive
- 1 x 0 to 10VDC analogue output capable of driving a 10kΩ load
- 240VAC power supply

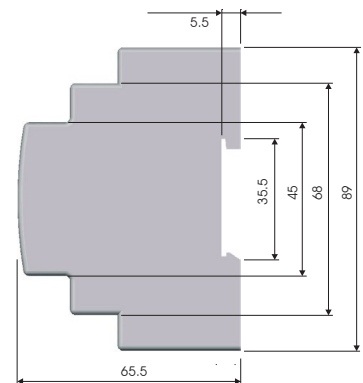
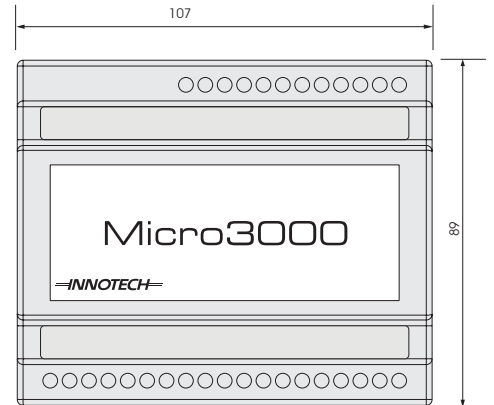
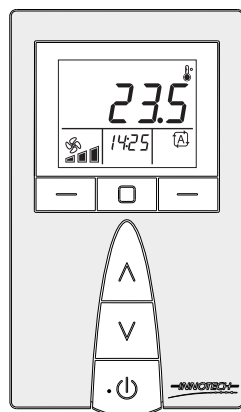
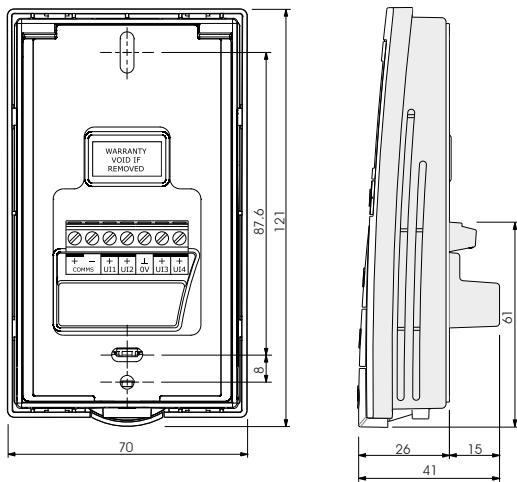

## Installation / Wiring

The *Control Station* should be installed in an environment that does not exceed the maximum operating parameters of the device. It should be mounted in a clean and dry environment free of vibration, and properly ventilated.

The cable providing both power for the *Control Station* and communication must be 2 core shielded twisted pair cable. Polarity (+/-) MUST be observed when connecting power.

The recommended cable length between the *Controller* and the *Control Station* is maximum 30 metres.

The wiring between these devices should not be run in parallel with conductors carrying high current.

The *Controller* should be mounted on DIN rail in cabinets approved for switchgear or industrial control equipment. Maximum terminal cable entry is 1.5mm<sup>2</sup>. The *Control Station* should be mounted with a standard vertical C-Clip, or on a standard wall enclosure.

Wiring should be done in accordance with Innotech connection diagrams and local bylaws or refer to your local distributor.

Connect the 240VAC supply to the correct terminals on the *Controller*, observing the correct polarity of the connections. Connect the EARTH to the correct terminals on all units.

 This product should only be installed by qualified personnel.

## Specifications

### POWER SUPPLY REQUIREMENTS

Power Input	240VAC ±10% @ 50/60Hz
Power Consumption	16VA max

 Polarity L/N for *Controller* and (+/-) for the *Control Station* MUST be observed when connecting power.

### ENVIRONMENTAL

Operating Temperature	0 to 40°C non-condensing
Storage Temperature	0 to 50°C non-condensing

### BATTERY - M3K02 & M3K04 Only

Contains Lithium Type Battery, Dispose of Properly (in accordance with local regulations).

Type	CR-2032 Lithium
Nominal voltage	3 Volts
Shelf life	5 Years, depending on ambient temperature

 Risk of explosion if battery is replaced by an incorrect type.

### ENCLOSURE - CONTROL STATION

Designed to maximise airflow to the integrated temperature sensor. It should be mounted with a standard vertical C-Clip, or on a standard wall enclosure.

Colour	Grey / White
Dimensions (Maximum)	(W)70mm x (H)121mm x (D)41mm

### ENCLOSURE - CONTROLLER

Housed in a rectangular case suitable for DIN Rail mounting. Housing molded from flame retardant plastics recognised by UL as UL94-V0.

Colour	Grey
Dimensions (Maximum)	(W)107mm x (H)89mm x (D)65.5mm

### APPROVALS

EN61326-1:2013 for CE Marking and RCM Labelling

Designed and tested in accordance with IEC 61010-1, Edition 3.0: 2010 Safety Standard

## Inputs & Outputs

### INPUTS / OUTPUTS - CONTROL STATION

#### ONBOARD TEMPERATURE SENSOR

1 x Onboard Temperature Sensor	
Sensing Range	-20°C to 100°C (96kΩ to 677Ω)
Nominal Sensing Range	-5°C to 60°C
Accuracy	±3.5%FS (R25°C = 10kΩ)

#### UNIVERSAL INPUTS - DIGITAL INPUTS OR OPTIONAL REMOTE TEMPERATURE SENSOR

4 Inputs configured as shown below:

Type	Sensing Range	Nominal Sensing Range	Accuracy
Remote Temperature Sensor  <sup>1</sup>	-20°C to 100°C (96kΩ to 677Ω)	-5°C to 60°C	±3.5%FS (R25°C = 10kΩ)
Dry Digital Input	Open or Closed	Open or Closed	ON or OFF

<sup>1</sup> Only available on Input 1, programmed in Parameter 17.

### INPUTS / OUTPUTS - CONTROLLER

#### AMBIENT TEMPERATURE SENSOR (Optional)

1 x Ambient Temperature Sensor	
Sensing Range	-20°C to 100°C (96kΩ to 677Ω)
Nominal Sensing Range	-5°C to 60°C
Accuracy	±3.5%FS (R25°C = 10kΩ)

#### ANALOGUE OUTPUT

1 x Analogue Output	
Output Range	0 to 10VDC
Output Accuracy	±0.1V (RLoad > 2kΩ)
Output Resolution	~40 mV

#### DIGITAL OUTPUTS

5 x Relay Outputs	
Rating Voltage	240VAC
Rating Current	16A resistive, 6A inductive

## Status LEDs

### CONTROLLER

LED Indicator	LED Colour	Description
Power	Red	Power is ON
Communication	Red	Data Transmit
	Green	Data Receive

## Micro 3000 Parameters

The parameters can be accessed and programmed by simultaneously pressing and holding the **Power**, **Left** and **Right** buttons on the *Control Station*. You may modify multiple parameters before returning to the primary display to save the changes.

**i** You must use the **Left** button to exit and return to the primary display in order to save any parameter changes to memory.

**t** After 60 seconds of inactivity, the *Control Station* will return to the Primary Display without saving any changes.

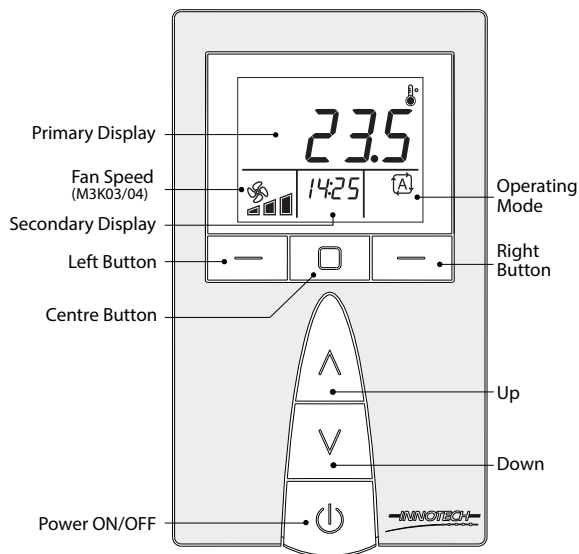

### Parameter 1: Room Temp Sensor Calibration Value

This applies an offset to either the onboard temperature sensor or optional remote temperature sensor wired to Input 1 of the *Control Station*. Use the **Up** and **Down** buttons to modify the offset. The display will show the current temperature with the offset applied.

### Parameter 2: Setpoint Minimum Value

This parameter sets the minimum value for the setpoint. The factory default setting is 15°C.

### Parameter 3: Setpoint Maximum Value

This parameter sets the maximum value for the setpoint. The factory default setting is 30°C.

**t** If P3=P2, the setpoint will be locked from the user at the current setpoint value.

### Parameter 4: Dead Band

This parameter sets the desired Dead Band range.

- The range of Dead Band is 0 to 10°C
- The factory default setting is 0.5°C (0.25°C either side of setpoint)

### Parameter 5: Proportional Band

This parameter sets the desired Proportional Band setting. A Proportional Band setting of 2°C will result in a differential of 2°C for heating and 2°C for cooling.

- The range of Proportional Band is 0 to 10°C
- The factory default setting is 1.5°C

### Parameter 6: Compressor Minimum Off Time

This determines the minimum time the compressor must remain off before it can restart.

- The range of the Compressor Minimum Off Time is 0 to 99 minutes
- The factory default setting is 4 minutes

### Parameter 7: Fan Run on Timer

This determines the period of time the fan will run for when heating in Electric Heat Mode (EDH) and the *Controller* is turned off.

- The range of the Fan Run on Timer is 0 to 10 minutes
- The factory default setting is 30 seconds

### Parameter 8: EDH / Rev Mode

This determines if the *Controller* will operate in Electric Heat Mode or Reverse Cycle Mode.

- In Electric Heat Mode (EDH), the heating and cooling relays operate independently
- In Reverse Cycle Mode (REV), the cooling relays control the compressor in both heating and cooling operations. The heating relays operate the reversing valves
- The factory default setting is Electric Heat Mode

### Parameter 9: Rev Cycle Heating or Cooling

This determines when the reversing valve is energised. (Depending if P8 is set to Reverse Cycle Mode)

- COOL: the heating relays close during cooling
- HEAT: the heating relays close during heating
- The factory default setting is Heat

### Parameter 10: Fan Cycle

This determines whether the fan runs continuously or cycles with heating.

- ON: Fan cycles with heating
- OFF: Fan runs continuously
- The factory default setting is OFF

### Parameter 11: Supply Air Fan Status Timer

If the Supply Air Fan (SAF) Status is selected as an input, this parameter determines the time the controller will wait before acting on the SAF Status condition. **This parameter applies to P17 to P20.**

- The M3K will display an alarm if the Supply Fan output is on and the input is off, after the preset time delay.
- The SAF Timer can be set between 0 and 10 minutes
- The factory default setting is 0 (OFF)

### Parameter 12: Set Temperature Display Units

This determines whether the temperature is displayed in Celsius or Fahrenheit. The factory default setting is Celsius (°C).

### Parameter 13: Set Primary Display Mode

This parameter determines what is shown on the primary display. The factory default setting is the Room Temperature.

The Options are Time, Date, Control (CTRL), Setpoint (SP), Room Temperature (ROOM), Ambient Temperature (Ambt) and Analogue Output (AO-1). (Time & Date not shown in the M3K01 & M3K03 models)

### Parameter 14: Set Secondary Display Mode

This parameter determines what is shown on the secondary display.

#### Factory Defaults

- M3K01 & M3K03 - Setpoint
- M3K02 & M3K04 - Time

The Options are Time, Date, Control (CTRL), Setpoint (SP), Room Temperature (ROOM), Ambient Temperature (Ambt) and Analogue Output (AO-1). (Time & Date not shown in the M3K01 & M3K03 models)

### Parameter 15: Analogue Output Function

This determines whether the Analogue Output (AO) operates for Cooling, Heating, Economy Cycle or 1st stage Compressor.

- The factory default setting is Cooling

 If Economy is set, Economy mode is active when enabled by an input or when the ambient temperature is less than the room temperature.

 If set to 1st stage Compressor, and Reverse Cycle Mode is selected in Parameter 8, the AO will respond as 1st stage of cooling and heating.

### Parameter 16: Ambient Sensor Calibration Value

This applies an offset to the Ambient Air Sensor wired to the Controller. Use the **Up** and **Down** buttons to modify the offset. The display will show the current temperature with the offset applied.

### Parameter 17-20: Inputs 1-4

This determines the function of the inputs.

#### Input 1-4

[Control Station Display Text in Brackets] (**Default Input in Bold**)

- After Hours Pushbutton [AHRS] - Pulse On/Off (**Def. Input 2/P18**)
- Disable – External Disable [dSbL] - Disables all outputs
- Door Switch [door] - Disables all outputs after the P24 time delay
- Economy Enable [Econ] - Enabled when input is on
- Enable – External Enable [ENbL] (**Def. Input 1/P17**)
- Fault (of which the following can be selected):
  - q. Compressor Fault [CMPR] - Displays message
  - r. Condenser Water Fault [Cond] - Disables all outputs (except fan)
  - s. Flood Sensor Fault [FSF] - Disables all outputs (except fan)
  - t. General Fault [GEN] - Displays message (**Def. Input 3/P19**)
  - u. Heater Protection Thermostat Fault [HPt] - Displays message
  - v. Supply Air Fan Status [SAF] - Disables all outputs (except fan)  
Refer to P11 for more details.
  - w. Unit Fault [Unit] - Displays message
- Key Switch [KEY] - Disables all outputs
- Load Shed [LS] - Disables outputs set in P23
- Remote Temperature Sensor [Room] (Parameter 17 only)
- Standby/Occupied [StbY] (**Def. Input 4/P20**)

### Parameter 21: Standby Dead Band

This determines a Standby or Secondary Dead Band setting. (Only when a DI is set to Standby)

- The range of the Dead band setting is OFF to 10°C
- The factory default setting is 6°C

### Parameter 22: Standby Setpoint

This determines a Standby or Secondary Setpoint. (Only when a DI is set to Standby)

- The factory default setting is OFF
- Range: OFF to [Min SP=P2 / Max SP=P3]

### Parameter 23: Load Shed

This parameter determines the functionality of the Load Shed input. (Only when a DI is set to Load Shed in parameter 17 to 20) The following actions can be selected:

- ALL – Disables all outputs (except fan)
- LSAC – Disables all cooling (except fan)
- LSAH – Disables all heating (except fan)
- LSC2 – Disables cooling stage 2 (except fan)
- LSH2 – Disables heating stage 2 (except fan)
- The factory default setting is ALL

### Parameter 24: Door Open Timer

This determines the period of time before the door is registered as open. (**When any DI is set to Door Switch**)

- The range of the door open time is 0 to 10 minutes
- The factory default setting is 30 seconds

### Sensor Faults

There are two faults that may be displayed under certain conditions:

- **Check Sensor Type** - A remote sensor is detected on Input 1 and Parameter 17 is not set to "Room".
- **Sensor Fault** - Parameter 17 is set to "Room" and no remote sensor is detected.

### Startup Defaults

Hold the **Centre** and **Right** buttons to Set Default Startup Values. The current settings are saved and the settings will be retained in case of power loss.

### Reset To Factory Defaults

The Control Station can be reset back to the factory settings.

Resetting the Defaults will clear the schedules and set the parameters back to the factory defaults. Follow these steps to reset the Control Station. **The Control Station must match the Controller.**

1. Hold the **Left**, **Right** and **On/Off** buttons for five seconds to enter the Parameters menu.
2. Hold the **Up**, **Down** and **On/Off** buttons for two seconds until RSET is displayed.
3. Use the **Up** and **Down** buttons to select the model.
4. Hold the **Entr** button for approximately four seconds until RSET stops flashing. The Control Station will then restart with the default settings.

 <sup>1</sup> Each Digital Input in parameter 17-20 can only be selected once in the Control Station. ie. If the After Hours Pushbutton DI is selected in Parameter 18, it cannot be selected for the other Inputs P17, P19 or P20.

 <sup>2</sup> If four dashes are displayed on the Control Station, the parameter is unavailable in the current configuration.

### M3K01/M3K02 Electric Heat Connection Diagram

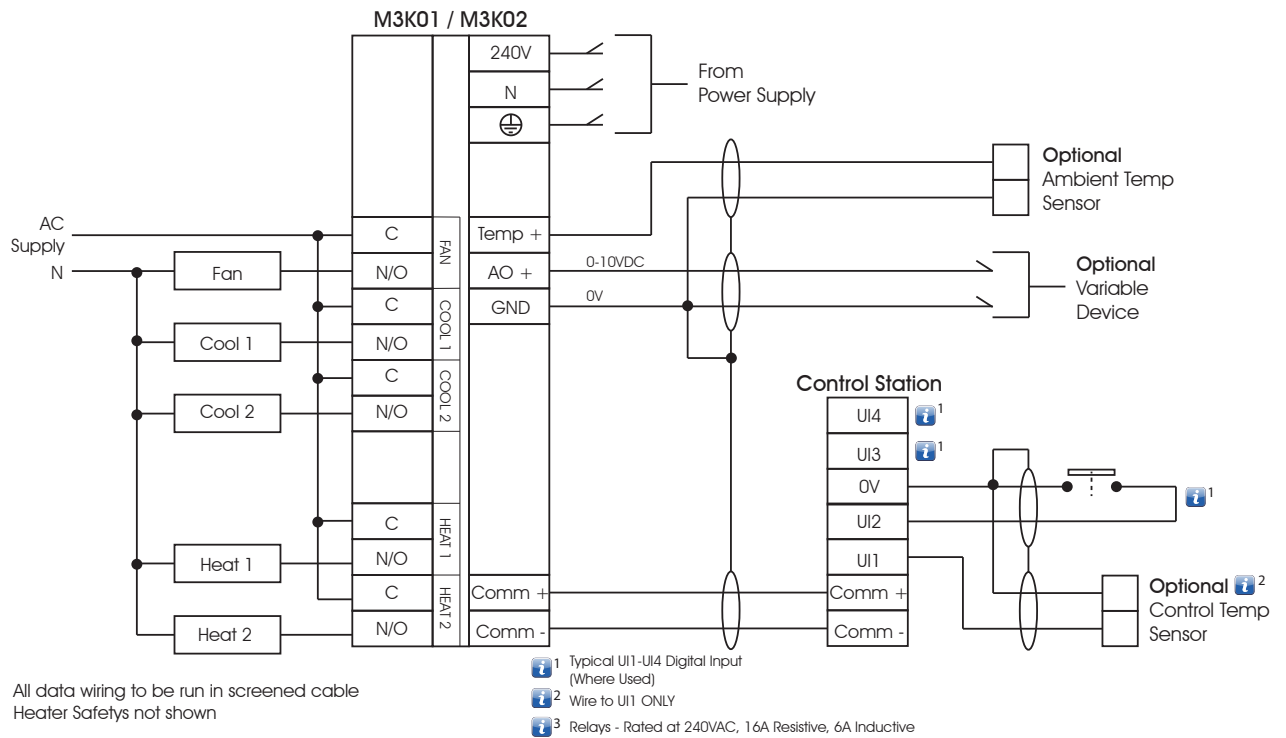

### M3K03/M3K04 Electric Heat Connection Diagram

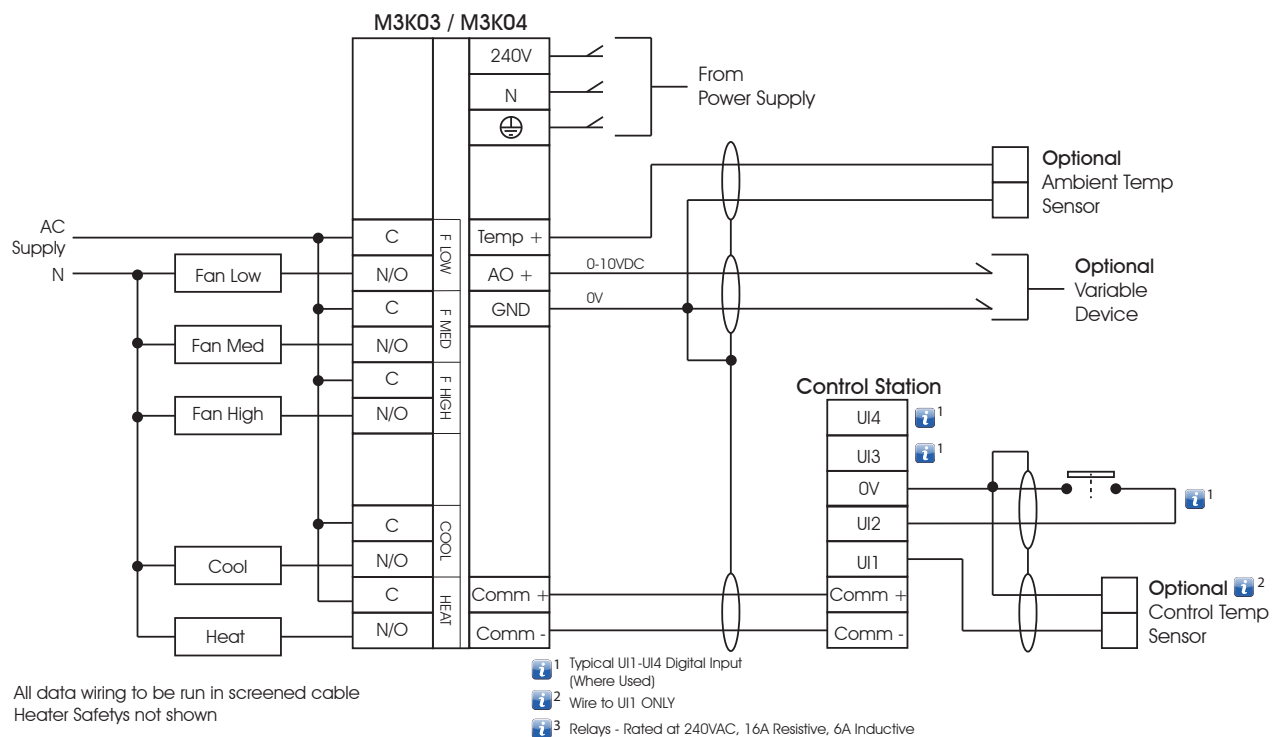

### M3K01/M3K02 Reverse Cycle Connection Diagram

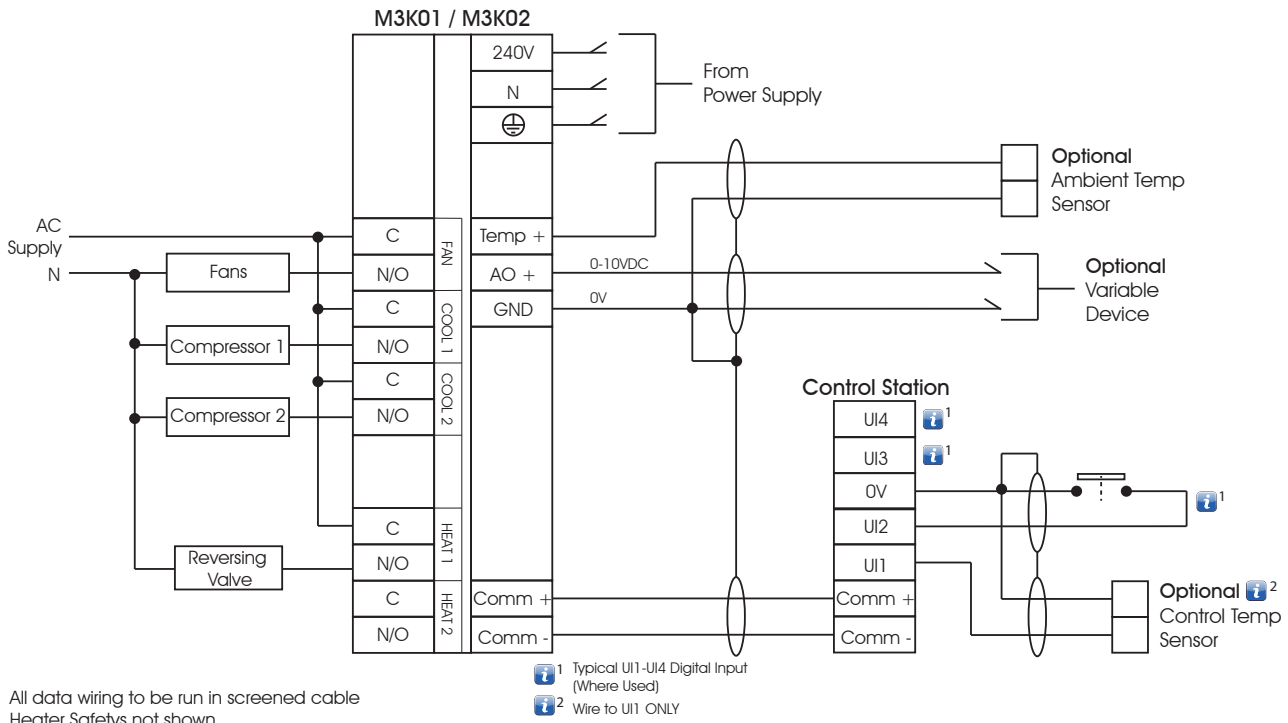

### M3K03/M3K04 Reverse Cycle Connection Diagram

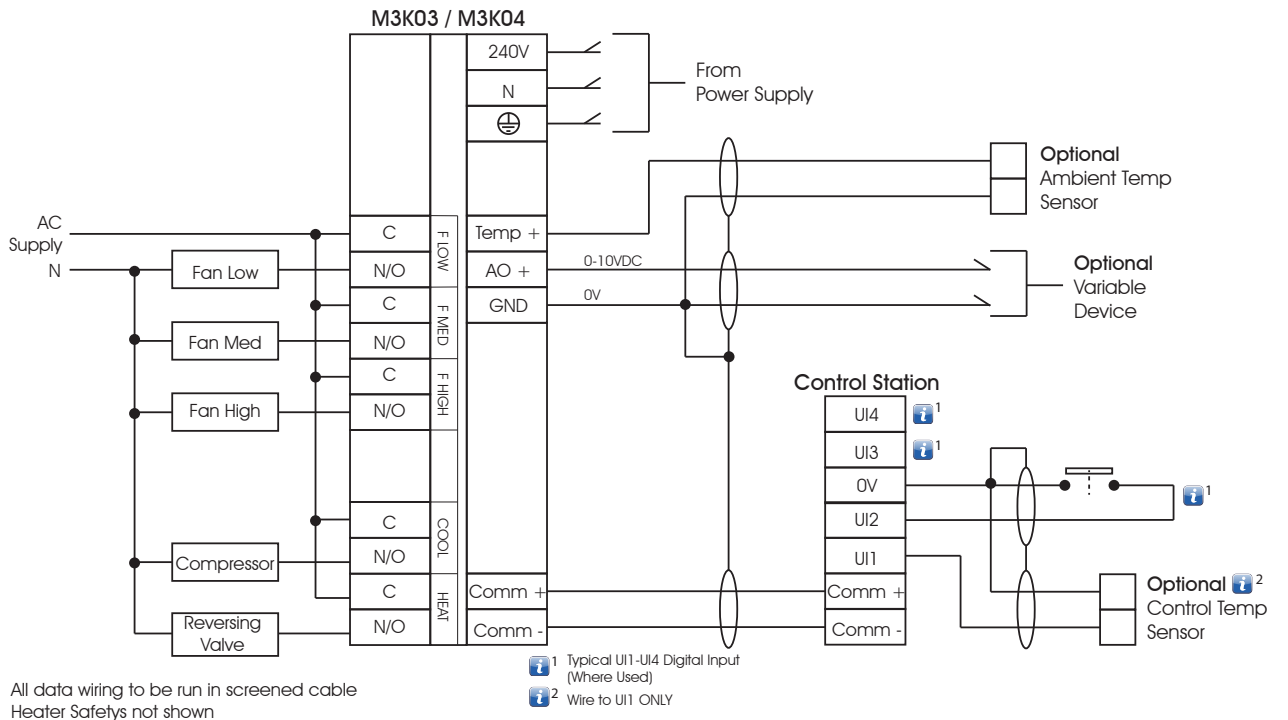

Australian Owned, Designed & Manufactured  
 by Mass Electronics Brisbane

Phone: +61 7 3421 9100 Fax: +61 7 3421 9101  
 Email: sales@innotech.com.au www.innotech.com.au

YOUR DISTRIBUTOR